

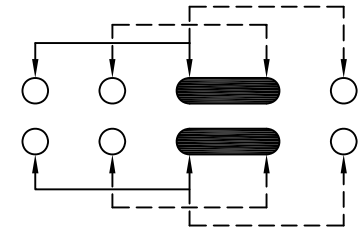

CAD FILE:

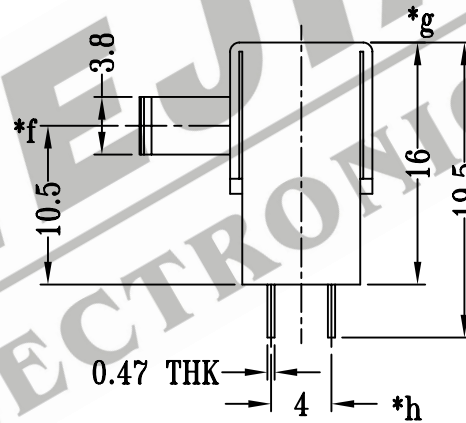

SCHMATIC (SHORTING)

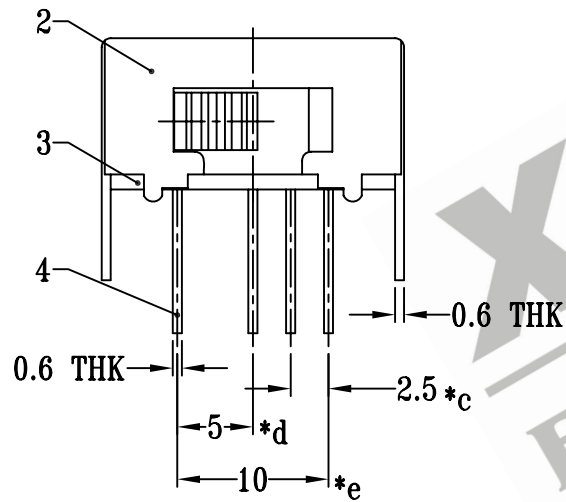
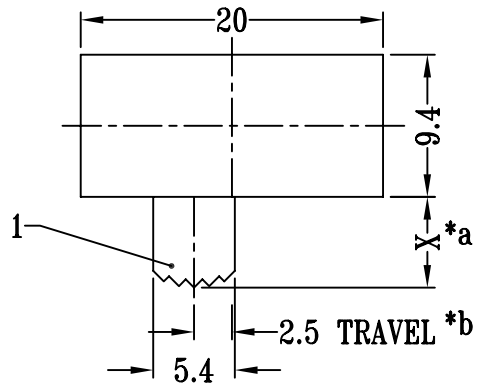
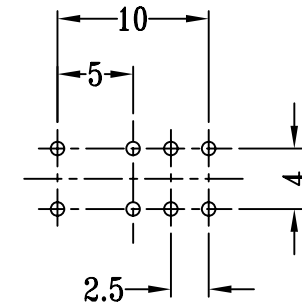

P.C.B LAYOUT

注:带"*"表示关键尺寸(8个)

8					TOLERANCE UNLESS SPECIFIED	SHENZHEN XIEJIA ELECTRONICS CO.,LTD.				
7	STEEL STRIP	STEEL	1	NATURAL	WITHIN: 1.5±0.1mm OVER: 1.5±0.2mm	ISSUE	DATE	DESCRIPTIONS		APPD
6	SPRING	STAINLESS STEEL	1	TEMPER						
5	CONTACT (CLIP)	PBS STRIP	2	Ag PLATED	TITLE: HORIZONTAL SLIDE SWITCH UNIT : MM DRWG NO.: XJ-DR-SK23E13-00					
4	TERMINAL	BRASS STRIP	8	Ag PLATED OVER Ni PLATED						
3	TERMINAL BASE	PHENOLIC RESIN	1	NATURAL	MODEL: SK-23E13		SCALE: 2:1	DWN	ZHOUYU	2006-9-13
2	FRAME	STEEL STRIP	1	Ni PLATED				CHK'D	FANGYING	2006-9-13
1	KNOB	POM	1	BLACK	ALL MATERIALS MUST BE COMPLIANT TO ROHS					
NO.	PART NAME	MATERIAL	QTY	FINISHING						